

E n g i n e e r ■ B u i l d ■ P e r f o r m ■ E x c e e d

 EGYCAMP

cargopro

Offshore Cargo Carrying Units



**BUREAU
VERITAS**

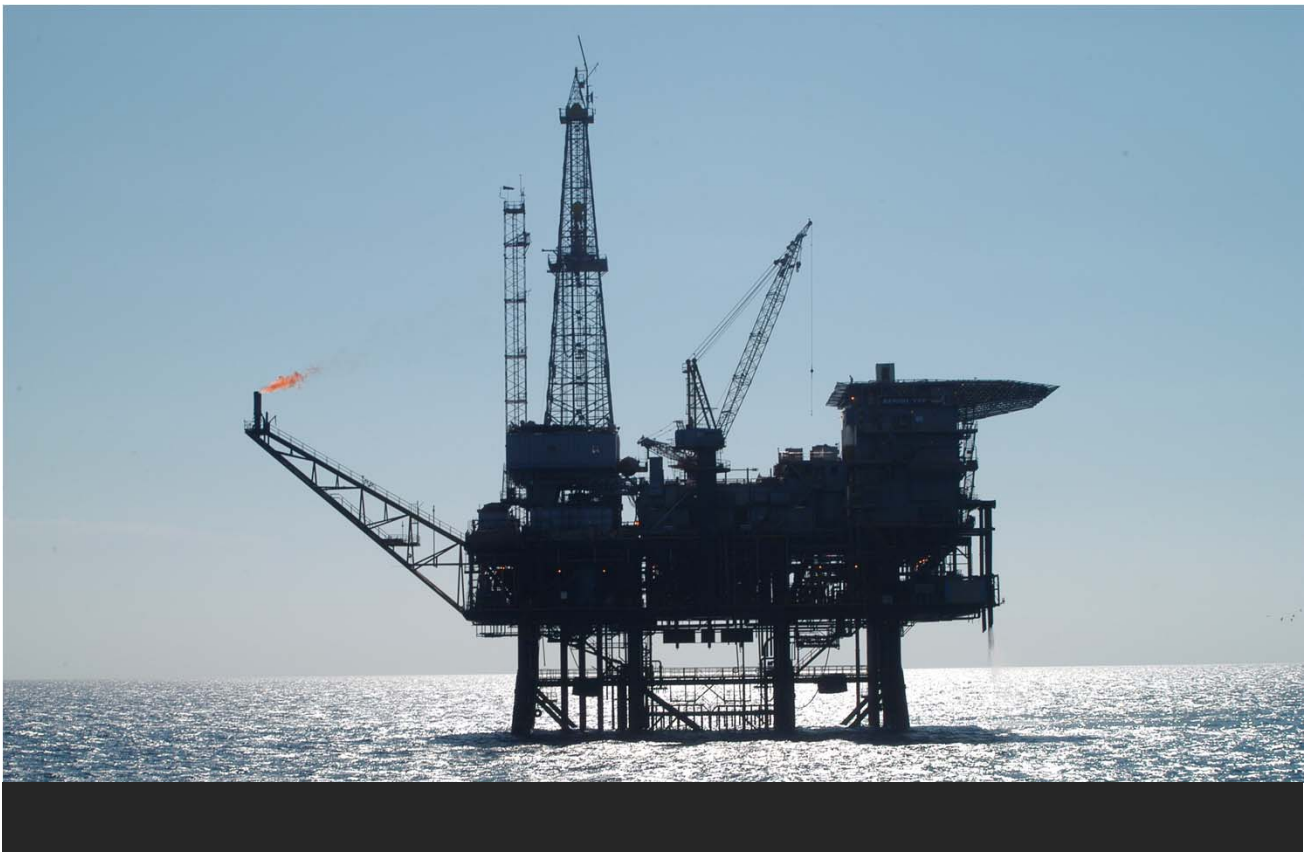

DNV 2.7-1/BS 12079 Mini Container

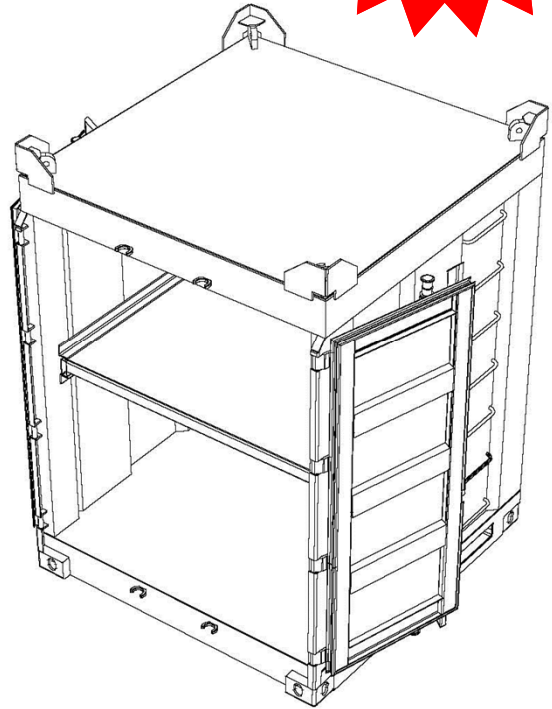
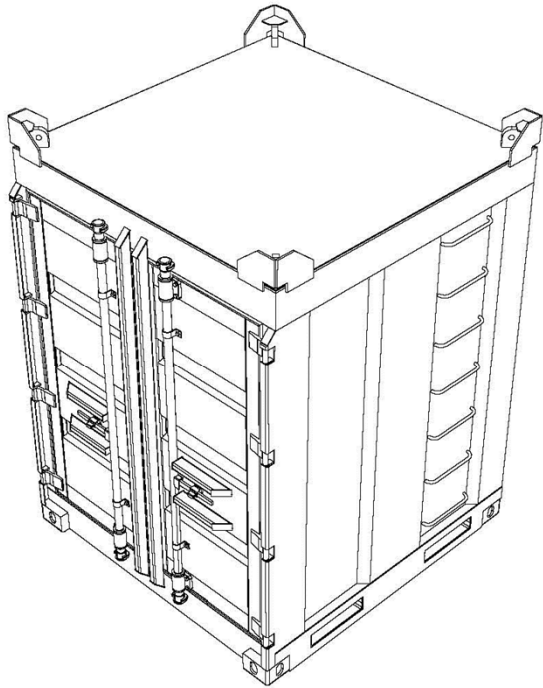

Product code: CP-01

Overview	Offshore mini containers are suitable for transporting chemicals, big bags, barrels and other goods to & from offshore oil rigs.															
Features	<ul style="list-style-type: none"> <input type="checkbox"/> DNV 2.7-1/BS 12079 certified appraised design by Bureau Veritas <input type="checkbox"/> Various sizes (standard, tall and extra tall) <input type="checkbox"/> Stackable design <input type="checkbox"/> Protected padeye <input type="checkbox"/> Internal and external Tie points 	<ul style="list-style-type: none"> <input type="checkbox"/> Certified ISO bottom corner <input type="checkbox"/> Side ladder <input type="checkbox"/> Protected hinges and locks <input type="checkbox"/> Sealed water proof door <input type="checkbox"/> Pin secured middle shelf <input type="checkbox"/> Drain hole <input type="checkbox"/> Safety net (Optional) <input type="checkbox"/> Lifting Set (Optional) 														
Weight and Dimensions	<table border="1" style="width: 100%; border-collapse: collapse;"> <tr> <td style="width: 30%;">Max. Gross weight (kg)</td> <td style="text-align: center;">6,600</td> </tr> <tr> <td>Tare Weight (kg)</td> <td style="text-align: center;">1,600</td> </tr> <tr> <td>Max. Pay Load (kg)</td> <td style="text-align: center;">5,000</td> </tr> </table>	Max. Gross weight (kg)	6,600	Tare Weight (kg)	1,600	Max. Pay Load (kg)	5,000	<table border="1" style="width: 100%; border-collapse: collapse;"> <tr> <td style="width: 30%;">External Dimensions</td> <td style="text-align: center;">1830 x 1830 x 2400</td> </tr> <tr> <td>L x W x H (mm)</td> <td></td> </tr> <tr> <td>Internal Dimensions</td> <td style="text-align: center;">1680 x 1680 x 2000</td> </tr> <tr> <td>L x W x H (mm)</td> <td></td> </tr> </table>	External Dimensions	1830 x 1830 x 2400	L x W x H (mm)		Internal Dimensions	1680 x 1680 x 2000	L x W x H (mm)	
Max. Gross weight (kg)	6,600															
Tare Weight (kg)	1,600															
Max. Pay Load (kg)	5,000															
External Dimensions	1830 x 1830 x 2400															
L x W x H (mm)																
Internal Dimensions	1680 x 1680 x 2000															
L x W x H (mm)																



DNV 2.7-1/BS 12079 10ft Closed Top Container

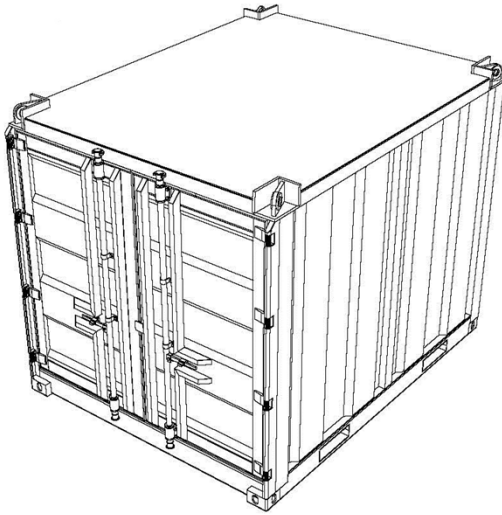
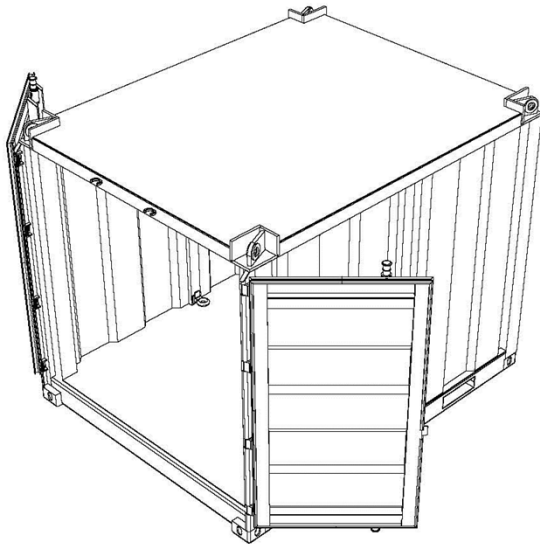

Product code: CP-02

Overview	Offshore Closed top containers are suitable for transporting tools, hoses and goods to & from offshore oil rigs.			
Features	<input type="checkbox"/> DNV 2.7-1/BS 12079 certified appraised design by Bureau Veritas <input type="checkbox"/> Stackable design <input type="checkbox"/> Protected padeye <input type="checkbox"/> Certified ISO bottom corner <input type="checkbox"/> Drain hole	<input type="checkbox"/> Side ladder <input type="checkbox"/> Protected hinges and locks <input type="checkbox"/> Sealed water proof door <input type="checkbox"/> Internal and external Tie points <input type="checkbox"/> Lifting Set (Optional)		
Weight and Dimensions	Max. Gross weight (kg)	10,500	External Dimensions	3000 x 2400 x 2600
	Tare Weight (kg)	2,500	L x W x H (mm)	
	Max. Pay Load (kg)	8,000	Internal Dimensions	2800 x 2200 x 2300
			L x W x H (mm)	



DNV 2.7-1/BS 12079 10ft Open Top Container

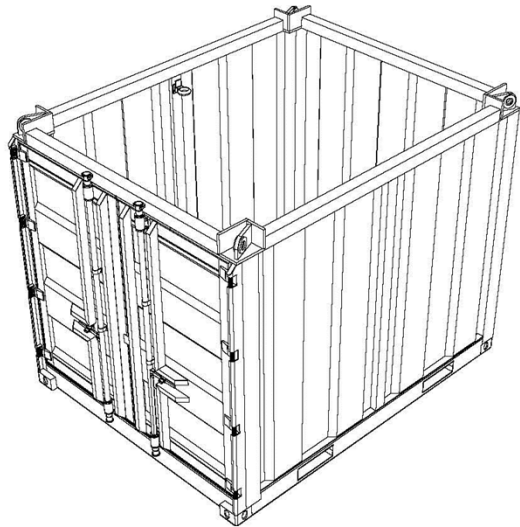
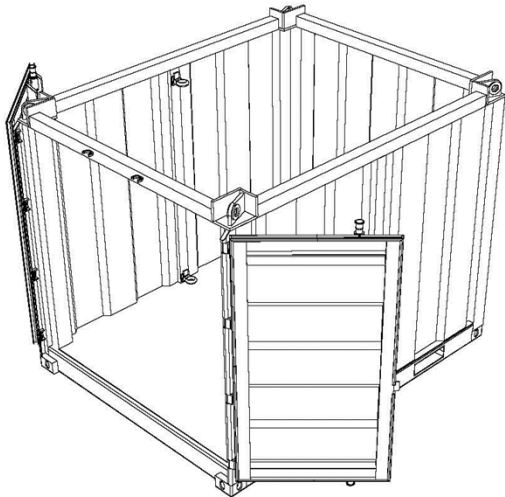

Product code: CP-03

Overview	Offshore Open top containers with easy crane access are suitable for transporting tools, hoses and goods to & from offshore oil rigs.			
Features	<input type="checkbox"/> DNV 2.7-1/BS 12079 certified appraised design by Bureau Veritas <input type="checkbox"/> Stackable design <input type="checkbox"/> Protected padeye <input type="checkbox"/> Certified ISO bottom corner <input type="checkbox"/> Drain hole		<input type="checkbox"/> Side ladder <input type="checkbox"/> Protected hinges and locks <input type="checkbox"/> Sealed water proof door <input type="checkbox"/> Internal and external Tie points <input type="checkbox"/> Lifting Set (Optional) <input type="checkbox"/> Cargo net (Optional)	
Weight and Dimensions	Max. Gross weight (kg)	10,200	External Dimensions	3000 x 2400 x 2600
	Tare Weight (kg)	2,200	L x W x H (mm)	
	Max. Pay Load (kg)	8,000	Internal Dimensions	2800 x 2200 x 2300
			L x W x H (mm)	

cargopro
Offshore Cargo Carrying Units



**BUREAU
VERITAS**



DNV 2.7-1/BS 12079 20ft Closed Top Container

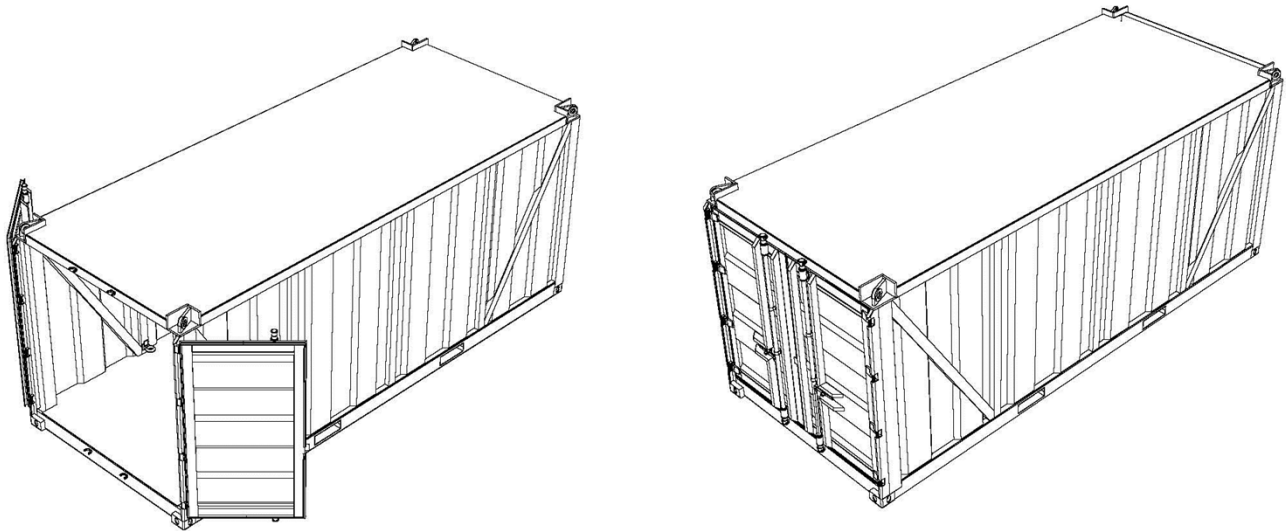

Product code: CP-04

Overview	Offshore Closed top containers are suitable for transporting tools, hoses and goods to & from offshore oil rigs.			
Features	<input type="checkbox"/> DNV 2.7-1/BS 12079 certified appraised design by Bureau Veritas <input type="checkbox"/> Stackable design <input type="checkbox"/> Protected padeye <input type="checkbox"/> Certified ISO bottom corner <input type="checkbox"/> Drain hole	<input type="checkbox"/> Side ladder <input type="checkbox"/> Protected hinges and locks <input type="checkbox"/> Sealed water proof door <input type="checkbox"/> Internal and external Tie points <input type="checkbox"/> Lifting Set (Optional)		
Weight and Dimensions	Max. Gross weight (kg)	20,000	External Dimensions	6000 x 2400 x 2600
	Tare Weight (kg)	5,000	L x W x H (mm)	
	Max. Pay Load (kg)	15,000	Internal Dimensions	5700 x 2100 x 2300
			L x W x H (mm)	



DNV 2.7-1/BS 12079 20ft Open Top Container

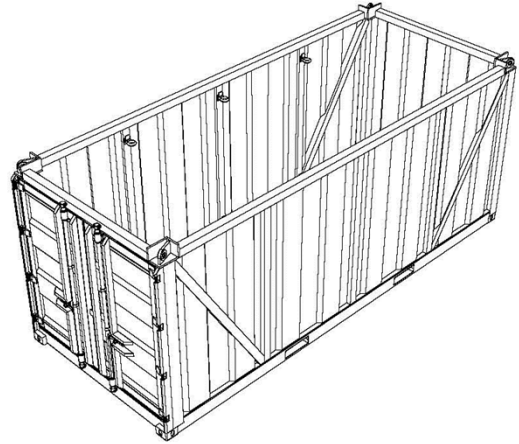
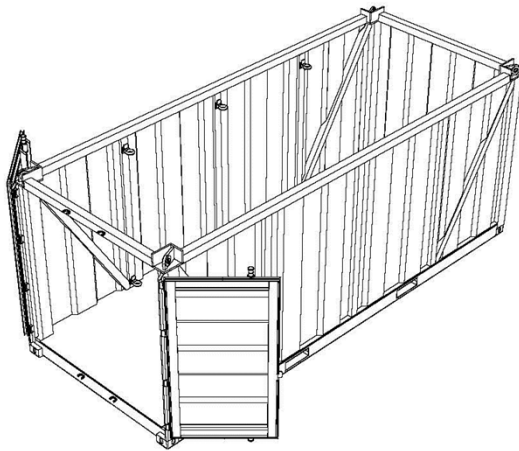

Product code: CP-05

Overview	Offshore Open top containers with easy crane access are suitable for transporting tools, hoses and goods to & from offshore oil rigs.			
Features	<input type="checkbox"/> DNV 2.7-1/BS 12079 certified appraised design by Bureau Veritas <input type="checkbox"/> Stackable design <input type="checkbox"/> Protected padeye <input type="checkbox"/> Certified ISO bottom corner <input type="checkbox"/> Drain hole	<input type="checkbox"/> Side ladder <input type="checkbox"/> Protected hinges and locks <input type="checkbox"/> Sealed water proof door <input type="checkbox"/> Internal and external Tie points <input type="checkbox"/> Lifting Set (Optional) <input type="checkbox"/> Cargo net (Optional)		
Weight and Dimensions	Max. Gross weight (kg) Tare Weight (kg) Max. Pay Load (kg)	19,500 4,500 15,000	External Dimensions L x W x H (mm) Internal Dimensions L x W x H (mm)	6000 x 2400 x 2600 5700 x 2100 x 2300



DNV 2.7-1/BS 12079 10ft Half Height Basket

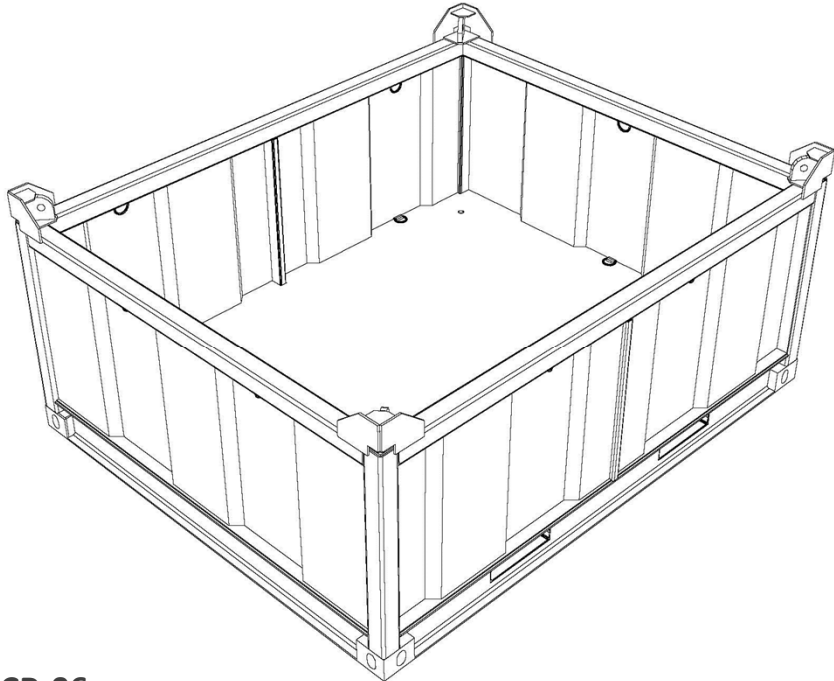

Product code: CP-06

Overview	Offshore baskets with easy crane access are suitable for transporting tools, hoses and goods to & from offshore oil rigs.			
Features	<input type="checkbox"/> DNV 2.7-1/BS 12079 certified appraised design by Bureau Veritas <input type="checkbox"/> Stackable design <input type="checkbox"/> Protected padeye <input type="checkbox"/> Certified ISO bottom corner <input type="checkbox"/> Drain hole	<input type="checkbox"/> Internal and external Tie points <input type="checkbox"/> Lifting Set (Optional) <input type="checkbox"/> Cargo net (Optional) <input type="checkbox"/> Fixed or removable top rail pin secured(Optional)		
Weight and Dimensions	Max. Gross weight (kg)	6,750	External Dimensions L x W x H (mm)	3000 x 2400 x 1200
	Tare Weight (kg)	1,750	Internal Dimensions L x W x H (mm)	2800 x 2200 x 1000
	Max. Pay Load (kg)	5,000		



DNV 2.7-1/BS 12079 40ft Half Height Basket

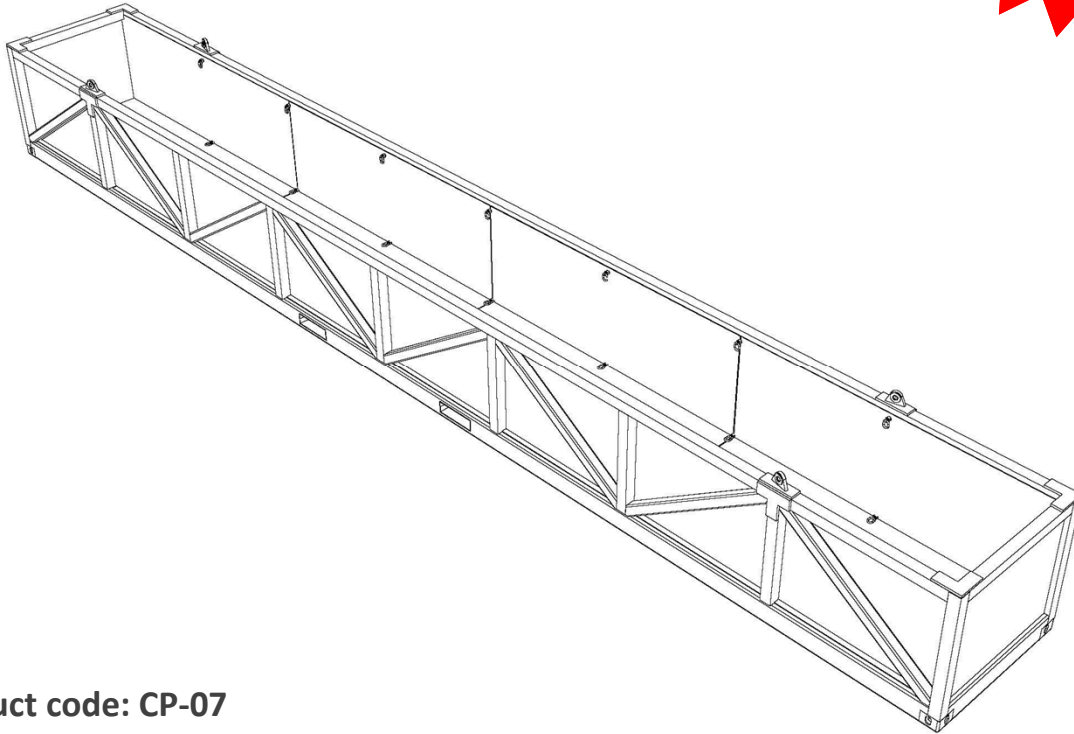

Product code: CP-07

Overview	Offshore baskets with easy crane access are suitable for transporting tools, hoses, long pipes, drilling pipes and goods to & from offshore oil rigs.			
Features	<input type="checkbox"/> DNV 2.7-1/BS 12079 certified appraised design by Bureau Veritas <input type="checkbox"/> Stackable design <input type="checkbox"/> Protected padeye <input type="checkbox"/> Certified ISO bottom corner <input type="checkbox"/> Drain hole		<input type="checkbox"/> Internal and external Tie points <input type="checkbox"/> Lifting Set (Optional) <input type="checkbox"/> Cargo net (Optional) <input type="checkbox"/> Supports for pipes (Optional) <input type="checkbox"/> Wooden pipe supports (Optional)	
Weight and Dimensions	Max. Gross weight (kg)	13,500	External Dimensions	12000 x 1200 x 1200
	Tare Weight (kg)	3,500	L x W x H (mm)	
	Max. Pay Load (kg)	10,000	Internal Dimensions	11700 x 900 x 1000
			L x W x H (mm)	



DNV 2.7-1/BS 12079 6x, 12x, 16x Bottle Rack

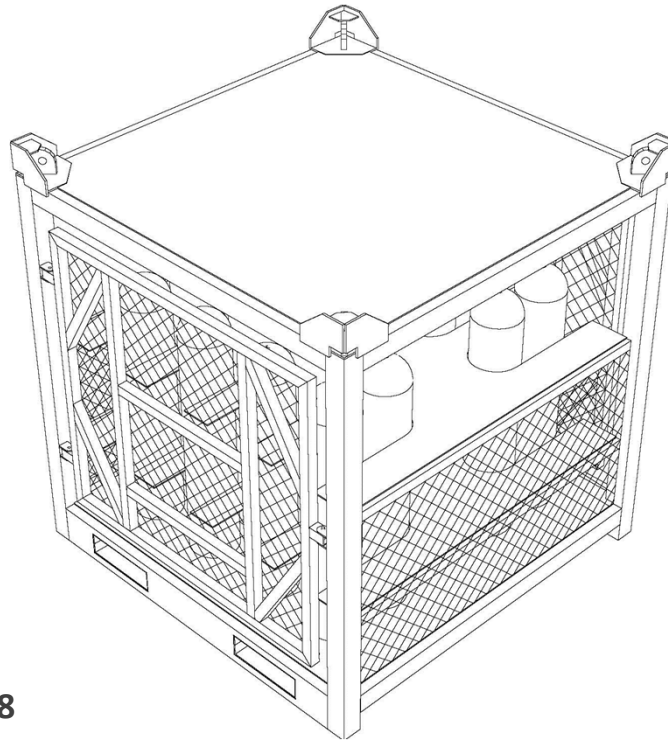

Product code: CP-08

Overview	Offshore bottle racks are suitable for transporting Oxygen, acetylene and nitrogen cylinders to & from offshore oil rigs.			
Features	<input type="checkbox"/> DNV 2.7-1/BS 12079 certified appraised design by Bureau Veritas <input type="checkbox"/> Variables sizes <input type="checkbox"/> Stackable design <input type="checkbox"/> Protected padeye <input type="checkbox"/> Secured doors by pins	<input type="checkbox"/> Secured chains with lock pin <input type="checkbox"/> Side mesh for clear internal vision <input type="checkbox"/> Internal and external Tie points <input type="checkbox"/> Lifting Set (Optional)		
Weight and Dimensions	Max. Gross weight (kg)	3,000	External Dimensions	1500 x 1200 x 2000
	Tare Weight (kg)	1,000	L x W x H (mm)	
	Max. Pay Load (kg)	2,000	Internal Dimensions	1300 x 1000 x 1700
			L x W x H (mm)	



DNV 2.7-1/BS 12079 Mud Skip

**SALE OR
RENTAL**

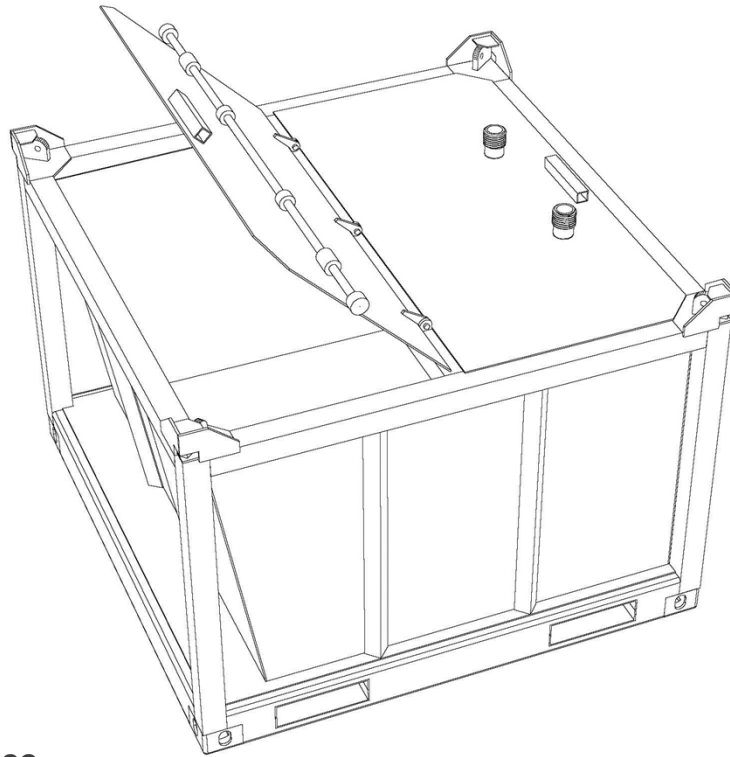

Product code: CP-09

Overview	Offshore Mud skips are suitable for transporting mud or oil to & from offshore oil rigs.			
Features	<input type="checkbox"/> DNV 2.7-1/BS 12079 certified appraised design by Bureau Veritas <input type="checkbox"/> Variables sizes <input type="checkbox"/> Stackable design <input type="checkbox"/> Protected padeye <input type="checkbox"/> Secured sealed top door	<input type="checkbox"/> Protected hinges and lockers <input type="checkbox"/> 2 way forklift pocket <input type="checkbox"/> 2 Vacuum nozzles with aluminum plug secured by chain <input type="checkbox"/> Side padeyes to allow tilting <input type="checkbox"/> Lifting Set (Optional)		
Weight and Dimensions	Max. Gross weight (kg)	6,500	External Dimensions	2000 x 2000 x 1500
	Tare Weight (kg)	1,500	L x W x H (mm)	
	Max. Pay Load (kg)	5,000	Internal Dimensions	1800 x 1800 x 1300
			L x W x H (mm)	(4m ³)

cargopro
Offshore Cargo Carrying Units



EGY CAMP

T: +20 2 2447 3121/2

F: +20 2 2447 3056

E: sales@egycamp.com

W: www.egycamp.com

DNV 2.7-1/BS 12079 Tote Tank

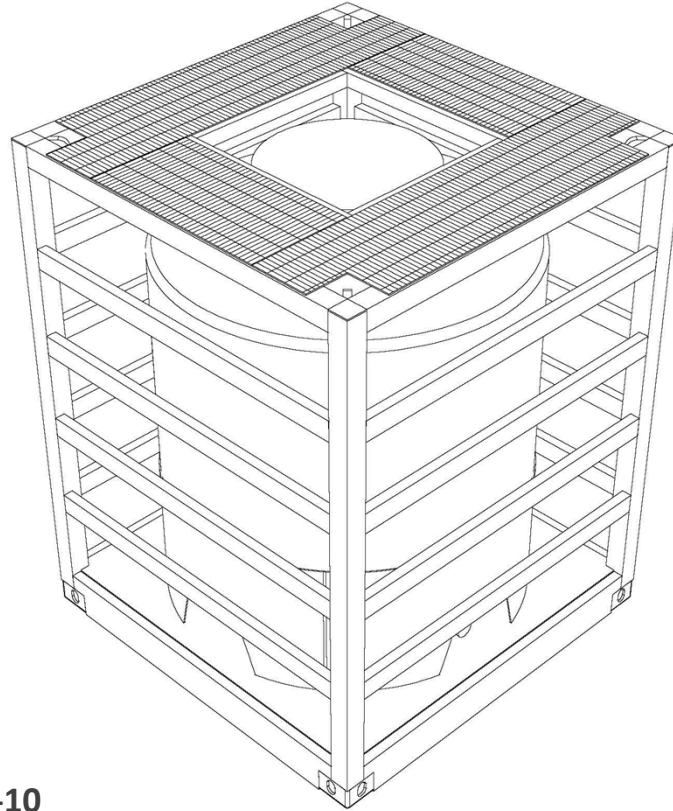

Product code: CP-10

Overview	Offshore Tote tank are suitable for transporting water, oil and low viscous fluids to & from offshore oil rigs.			
Features	<input type="checkbox"/> DNV 2.7-1/BS 12079 certified appraised design by Bureau Veritas <input type="checkbox"/> Variables sizes <input type="checkbox"/> Stackable design <input type="checkbox"/> Protected padeye <input type="checkbox"/> Bottom iso corners	<input type="checkbox"/> 2 way forklift pocket <input type="checkbox"/> Movable roof grating <input type="checkbox"/> 24" manhole <input type="checkbox"/> 2" inlet and outlet w/valves and plugs <input type="checkbox"/> Level indicator <input type="checkbox"/> Lifting Set (Optional)		
Weight and Dimensions	Max. Gross weight (kg)	10,000	External Dimensions	1950 x 1950 x 2600
	Tare Weight (kg)	2,400	L x W x H (mm)	
	Max. Pay Load (kg)	7,600	Internal Dimensions	1800 x 1800 x 2300
			L x W x H (mm)	(4000 Liter)

cargopro
Offshore Cargo Carrying Units



DNV 2.7-1/BS 12079

ISO Tank

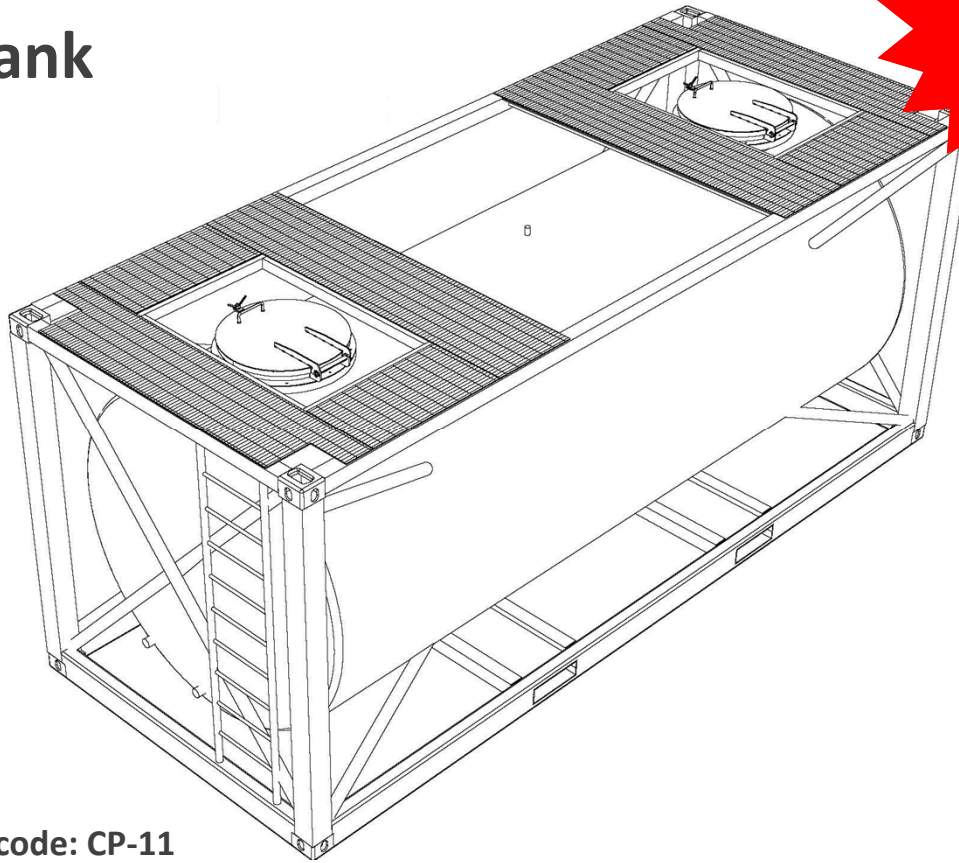

Product code: CP-11

Overview	Offshore Iso tank are suitable for transporting with safe and quick connections to fill and empty water, oil and low viscous fluids to & from offshore oil rigs.			
Features	<ul style="list-style-type: none"> <input type="checkbox"/> DNV 2.7-1/BS 12079 certified appraised design by Bureau Veritas <input type="checkbox"/> Variables sizes <input type="checkbox"/> Stackable design <input type="checkbox"/> Protected padeye <input type="checkbox"/> Top & Bottom iso corners <input type="checkbox"/> Insulation cladding 	<ul style="list-style-type: none"> <input type="checkbox"/> Movable roof grating <input type="checkbox"/> 24" manhole <input type="checkbox"/> 2" inlet and outlet w/valves and plugs <input type="checkbox"/> Level indicator <input type="checkbox"/> Safety relief valve, temperature gauge <input type="checkbox"/> Lifting Set (Optional) 		
Weight and Dimensions	Max. Gross weight (kg)	32,000	External Dimensions	6000 x 2400 x 2600
	Tare Weight (kg)	4,000	L x W x H (mm)	
	Max. Pay Load (kg)	28,000	Internal Dimensions	2400 x 5900
			Diameter x L (mm)	(24000 Liter)

cargopro
Offshore Cargo Carrying Units



DNV 2.7-1/BS 12079 20ft Workshop Container

**SALE OR
RENTAL**

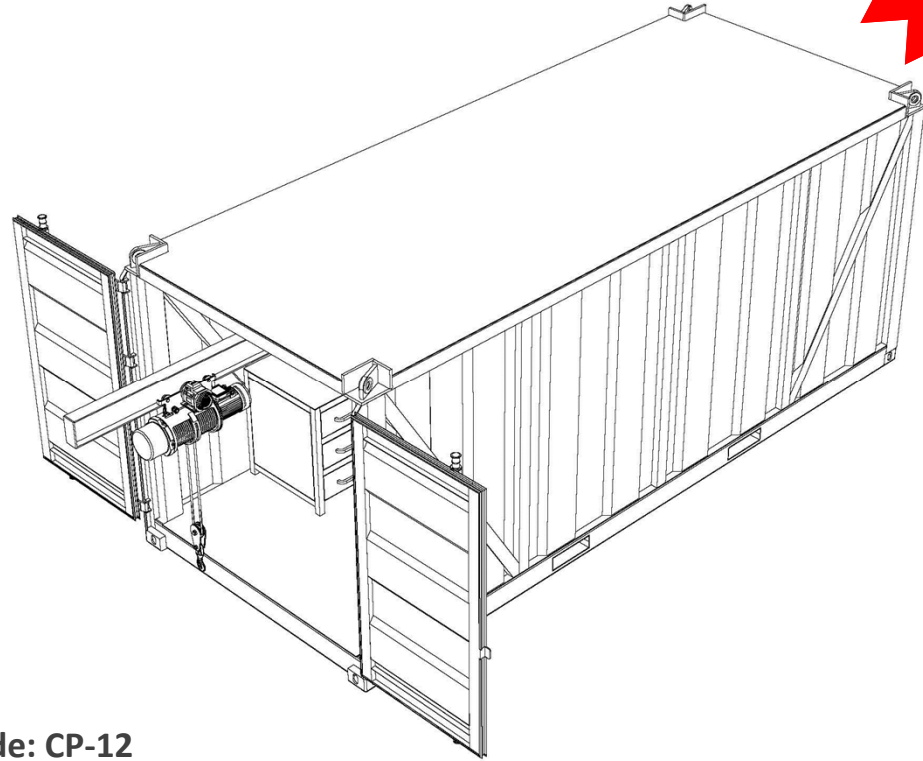

Product code: CP-12

Overview	Offshore Closed workshop containers are designed to provide facilities for personnel to maintain Remotely Operated Vehicles (ROVs) and storage facilities at offshore oil rigs.			
Features	<input type="checkbox"/> DNV 2.7-1/BS 12079 certified appraised design by Bureau Veritas <input type="checkbox"/> Stackable design <input type="checkbox"/> Protected padeye <input type="checkbox"/> Certified ISO bottom corner <input type="checkbox"/> Drain hole <input type="checkbox"/> Side ladder	<input type="checkbox"/> Protected hinges and locks <input type="checkbox"/> Sealed water proof door <input type="checkbox"/> Internal and external Tie points <input type="checkbox"/> Crane 1 ton <input type="checkbox"/> Shelving units <input type="checkbox"/> Lifting Set (Optional) <input type="checkbox"/> Lighting, electric work, AC's and escape door		
Weight and Dimensions	Max. Gross weight (kg)	10,000	External Dimensions	6000 x 2400 x 2600
	Tare Weight (kg)	5,500	L x W x H (mm)	
	Max. Pay Load (kg)	4,500	Internal Dimensions	5700 x 2100 x 2300
			L x W x H (mm)	





cargopro

Offshore Cargo Carrying Units

3082 Al Miraaj City; Basateen; Cairo, Egypt

T: +20 2 2447 3121/2

F: +20 2 2447 3056

E: sales@egycamp.com

W: www.egycamp.com